

## Robust Tunable *In Vitro* Transcriptional Oscillator Networks

Vishwesh V. Kulkarni<sup>\*</sup>, Theerachai Chanyaswad<sup>†</sup>, Marc Riedel<sup>◇</sup>, Jongmin Kim<sup>‡</sup>

**Abstract**—Synthetic biology is facilitating novel methods and components to build *in vivo* and *in vitro* circuits to better understand and re-engineer biological networks. Circadian oscillators serve as molecular clocks that govern several important cellular processes such as cell division and apoptosis. Hence, successful demonstration of synthetic oscillators have become a primary design target for many synthetic biology endeavors. Recently, three synthetic transcriptional oscillators were demonstrated by Kim and Winfree utilizing modular architecture of synthetic gene analogues and a few enzymes. However, the periods and amplitudes of synthetic oscillators were sensitive to initial conditions and allowed limited tunability. In addition, it being a closed system, the oscillations were observed to die out after a certain period of time. To increase tunability and robustness of synthetic biochemical oscillators in the face of disturbances and modeling uncertainties, a control theoretic approach for real-time adjustment of oscillator behaviors would be required. In this paper, assuming an open system implementation is feasible, we demonstrate how dynamic inversion techniques can be used to synthesize the required controllers.

### I. INTRODUCTION

An objective of synthetic biology is to build biological circuits from scratch, much like the synthesis of VLSI circuits using basic electronics components, and to interface these circuits with *in vivo* biological circuits. An example of such circuits is an oscillator. Biological oscillators serve as a time-keeping mechanism and control several important processes such as cell division and cell apoptosis. Since the underlying processes are rarely well modeled, the method used to synthesize the oscillations must be robust to modeling uncertainties (due to imprecisely known kinetic rates, number of molecules, etc.), thermal fluctuation, and intercellular noise. *In vitro* synthetic biology approaches allow researchers to directly access and manipulate biomolecular parts without the overwhelming complexity and intertwined dependencies within *in vivo* cellular circuits [1].

In [3], Elowitz and Leibler presented the first synthetic biological oscillator. This oscillator is obtained by implementing a network of three non-natural transcriptional repressor systems in *Escherichia coli*. Synthesis of a green fluorescent protein is the read out for the state of this network in individual cells. Since the oscillations reported in

<sup>\*</sup> University of Minnesota, Department of Electrical and Computer Engineering, Minneapolis, MN 55455; Email: vkulkarn@umn.edu.

<sup>†</sup> University of Minnesota, Department of Electrical and Computer Engineering, Minneapolis, MN 55455; Email: chany001@umn.edu.

<sup>◇</sup> University of Minnesota, Department of Electrical and Computer Engineering, Minneapolis, MN 55455; Email: mriedel@umn.edu. This research is supported, in parts, by the NSF CAREER Award 0845650, NSF CCF 0946601, and NSF CCF 1117168.

<sup>‡</sup> Department of Bioengineering, California Institute of Technology, Pasadena, CA; Email: jongmin@dna.caltech.edu. This research is supported, in parts, by NSF award 0832824 (The Molecular Programming Project).

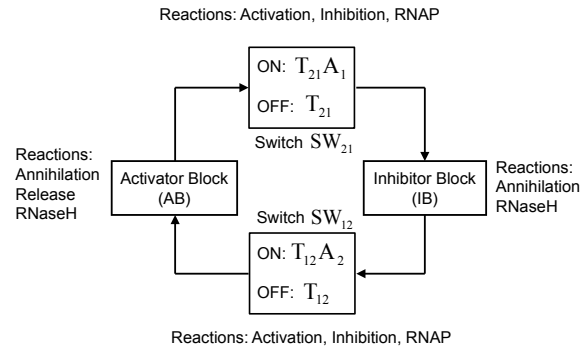

Fig. 1. The two-switch negative feedback oscillator synthesized in [2]. The coupled oscillator system comprises two switches (SW<sub>21</sub> and SW<sub>12</sub>), an inhibitor block (IB), and an activator block (AB). The ON state of the switch comprises DNA template T and an activator A bound together forming a complete promoter for T7 RNAP except for a nick. The OFF state template T contains an incomplete promoter for T7 RNAP. Each switch is realized using activation, inhibition, and RNAP. AB and IB are realized using annihilation, release, and RNaseH.

[3], with typical periods of hours, are slower than the cell-division cycle, the state of the oscillator gets transmitted from one generation to the next. A number of interesting synthetic biological oscillators have been synthesized since then (see, e.g., [4], [5], [6], [7], [8], [9], [10], [11], and references therein). Recently, modular synthetic gene analogues were used in [2] to synthesize three types of synthetic transcriptional oscillators *in vitro* using bacteriophage T7 RNA polymerase (RNAP) and *E. coli* ribonuclease H (RNase H): (1) a two-switch negative feedback oscillator, (2) an amplified negative feedback oscillator, and (3) a three-switch ring oscillator. These oscillators have since been used to drive DNA tweezers (see [12]). None of these designs, however, can produce sustained oscillations for an extended period of time and the oscillations are sensitive to the underlying parameters and initial conditions. Another relevant work is a DNA-based oscillator synthesized in [11]. However, it is not possible to pre-specify the robustness and the tunability of the oscillators synthesized in [2] and [11]. Furthermore, the oscillations are observed to die out within a few number of cycles due to enzyme inactivation, NTP fuel exhaustion, and buildup of wastes (see [2] and [11]). If the *closed system* nature of these oscillators is relaxed so that chemicals can be added and removed from the system then many of these hurdles can be overcome.

In this paper, assuming an *open system* implementation,

TABLE I  
NOTATION FOR THE OSCILLATOR CIRCUIT

Symbol	Meaning
$T$	dsDNA template + incomplete promoter
$T - A$	activated DNA template
$A - I$	functionally inert activator-inhibitor complex
$rA - I$	functionally inert activator-inhibitor complex
$T_{12}A_2$	ON-state $Sw_{12}$
$T_{12}$	OFF-state $Sw_{12}$
$T_{21}A_1$	ON-state $Sw_{21}$
$T_{21}$	OFF-state $Sw_{21}$
$[T_{ij}]$	Concentration of $T_{ij}$
$[T_{ij}^{tot}]$	$[T_{ij}] + [T_{ij}A_j]$
$rI$	free-floating ssRNA inhibitor
$dI$	free-floating ssDNA inhibitor
$rA$	free-floating ssRNA activator
$A$	free-floating ssDNA activator

we show how controllers synthesized using the principle of *dynamic inversion* (DI) (see [13]) can be used to resolve these problems. In particular, we demonstrate how a set of state variables of the network can be made to track an exogenous signal. If the exogenous signal is chosen to be a sinusoid or a pulse train, it follows that these state-variables will exhibit an oscillatory time-series response. It turns out that the DI controller is equivalent to a standard *proportional + integral* (PI) controller with a bias term which depends on the initial conditions. The DI controller ensures that the tracking error is of the same order of magnitude as the inverse of the proportional gain. Control theoretic synthesis of such DI controllers is explained in detail in [14] in the context of the repressilator network described in [3]. In this paper, we use the same ideas to build a feedback controller for the oscillator network described in [2], which is a more complicated and more advanced system. The novelty of this paper is not in the synthesis of DI controller but, rather, in applying the well-known DI controller synthesis results to a wet-lab implementation.

## II. SYSTEM DESCRIPTION

The reason why we focus on the oscillator synthesized in [2] (see Fig. 1) is that, in general, the DNA-based circuits relying on predictable thermodynamics and kinetics of DNA strand interactions impart a good deal of flexibility in synthesizing synthetic biological constructs and in coupling these circuits to *in vivo* processes. Here, a class of transcriptional circuits is modularly wired into arbitrarily complex networks by changing the regulatory and coding sequence domains of DNA templates. The transcriptional circuits can be wired as continuous-time analog neural networks with symmetric or asymmetric weights [15], implying that they are a computationally and behaviorally complete circuit architecture [16]. Individual transcriptional switches exhibit sharp sigmoidal inhibitory regulations so that the construction of two-switch circuits exhibiting bistable dynamics is possible [17].

Our system of interest is the two-switch oscillator of [2] shown in Fig. 1. It comprises two switches, denoted  $Sw_{12}$  and  $Sw_{21}$ , connected together in a negative feedback loop. The two switches take RNA regulators as the exogenous inputs and outputs. The switch response is governed by four DNA and RNA hybridization reactions, viz., activation, annihilation, inhibition, and release. The sharp thresholds from these hybridization reactions can be used to create a variety of analog or digital circuits [16]. The key hybridization reactions and toehold-mediated strand displacement reactions are summarized in Table II.

Specifically, each synthetic switch  $Sw_{ij}$  is controlled by an input signal, RNA species  $j$ , and produces an output signal, RNA species  $i$ . RNA activator  $rA_1$  activates the production of RNA inhibitor  $rI_2$  by modulating switch  $Sw_{21}$ , whereas RNA inhibitor  $rI_2$ , in turn, inhibits the production of RNA activator  $rA_1$  by modulating switch  $Sw_{12}$ . The OFF-state switch,  $T_{ij}$ , consists of a double-stranded DNA template with a single-stranded region containing an incomplete promoter for T7 RNAP. When a single-stranded DNA activator strand binds to the single-stranded region of template, the promoter region is complete except for a nick – this allows efficient transcription by RNAP, hence the switch turns into an ON-state. The switch can be turned OFF again by the addition of an inhibitor strand (either a single-stranded RNA ‘rI’ or single-stranded DNA ‘dI’) which initiates binding at the toehold domain of the activator strand and displaces the activator from the ON-state switch  $T_{ij}A_j$ . Free-floating inhibitor strands can also bind to complementary free-floating activator strands to form inert activator-inhibitor complexes. After these free-floating inhibitor and activator strands have bound together, there remains a certain amount of only inhibitor or activator strands, depending on which had a greater initial population. DNA activator strand  $A$  can be released from the  $A \cdot dI$  complexes when RNA activator strand  $rA$  displaces  $dI$  from  $A \cdot dI$  through toehold-mediated strand displacement reaction. The released activator is available to activate target switches. The catalytic production and degradation reactions are mediated by two enzymes: RNAP and RNase H. RNAP produces RNA signals from ON-state switches that in turn regulate the state of target switches, while RNase H degrades RNA signals within RNA-DNA hybrid complexes undoing the regulatory action by RNA signals.

## III. ODE MODEL OF THE SYSTEM

Let us assume that the experimental set-up ensures the following:

- The production rates of the two RNA signals are determined by ON-state switch concentrations;
- The degradation rates of the two RNA signals are determined by their own concentrations;
- Fixed RNAP and RNase H concentrations with first-order enzyme kinetics;
- Steady-state switch responses to RNA inputs ( $rA_1$  and  $rI_2$ ) can be approximated by Hill functions;

TABLE II  
KEY CHEMICAL REACTIONS IN THE OSCILLATOR (SEE [2])

Activation	Annihilation	RNAP
$T_{21} + A_1 \rightarrow T_{21}A_1$ $T_{12} + A_2 \rightarrow T_{12}A_2$	$A_1 + dI_1 \rightarrow A_1dI_1$ $rA_1 + dI_1 \rightarrow rA_1dI_1$ $A_2 + rI_2 \rightarrow A_2rI_2$	$T_{21}A_1 \rightarrow T_{21}A_1 + rI_2$ $T_{21} \rightarrow T_{21} + rI_2$ $T_{12}A_2 \rightarrow T_{12}A_2 + rA_1$ $T_{12} \rightarrow T_{12} + rA_1$
Inhibition	Release	RNaseH
$T_{21}A_1 + dI_1 \rightarrow T_{21} + A_1dI_1$ $T_{12}A_2 + rI_2 \rightarrow T_{12} + A_2rI_2$	$A_1dI_1 + rA_1 \rightarrow rA_1dI_1 + A_1$	$rA_1dI_1 \rightarrow dI_1$ $A_2rI_2 \rightarrow A_2$

- $K_I$  and  $K_A$  have been well approximated; and
- Hill coefficients have been well approximated.

Then, the system can be represented (see [2]) using the following *ordinary differential equations* (ODE's):

$$\begin{aligned} \frac{d[rA_1]}{dt} &= k_p \cdot [T_{12}A_2] - k_d \cdot [rA_1], \\ \frac{d[rI_2]}{dt} &= k_p \cdot [T_{21}A_1] - k_d \cdot [rI_2]. \end{aligned}$$

Let  $\Omega(x, y, n) \doteq \left( \frac{1}{1 + (\frac{x}{y})^n} \right)$ . Then, the response of the switch to the RNA inputs is given by (see [2]):

$$\begin{aligned} \frac{d[T_{12}A_2]}{dt} &= \frac{1}{\tau} ([T_{12}^{tot}] \Omega(rI_2, K_I, n) - [T_{12}A_2]), \\ \frac{d[T_{21}A_1]}{dt} &= \frac{1}{\tau} ([T_{21}^{tot}] (1 - \Omega(rA_1, K_A, m)) - [T_{21}A_1]). \end{aligned}$$

In the above equations,  $k_p$  represents the first-order rate constant based on RNAP, which produces RNA outputs, while  $k_d$  represents the first-order rate constant based on RNase H, which results in the degradation of RNA signals. Here,  $n$  and  $m$  are Hill exponents,  $\tau$  is a relaxation time for the hybridization reactions,  $K_A$  is the activation threshold for the RNA activator  $rA_1$ ,  $K_I$  is the inhibition threshold for the RNA inhibitor  $rI_2$ , and  $[T_{ij}^{tot}]$  is the sum of concentrations of all molecular species containing  $T_{ij}$ . Reasonable approximations for the thresholds are  $K_I \approx [A_2^{tot}] - \frac{1}{2}[T_{12}^{tot}]$  and  $K_A \approx [dI_1^{tot}] - [A_1^{tot}] + \frac{1}{2}[T_{21}^{tot}]$ , while reasonable approximations for Hill exponents are  $n \approx 4 \frac{K_I}{[T_{12}^{tot}]}$  and  $m \approx 4 \frac{K_A}{[T_{21}^{tot}]}$ . Hill exponents were measured experimentally in [17].

*Remark 1:* The difficulties in achieving sustained oscillations in closed systems are briefly stated in Section 1 and are described in detail in [2].  $\square$

#### IV. DI CONTROLLER SYNTHESIS

We shall demonstrate that sustained oscillations of desired amplitude and frequency can be induced in the oscillator network shown in Fig. 1 by synthesizing a suitable tracking controller. We shall synthesize the required tracking controller using the well-known principle of dynamic inversion. Control theoretic synthesis of such DI controllers is explained in

TABLE III  
NOTATION

Symbol	Meaning
$(\mathbb{R}^+)$	Set of all (nonnegative) real numbers
$\mathbb{R}^n$	Set of all $n$ -dimensional real-valued vectors
$\mathbb{R}^{n \times m}$	Set of all $n \times m$ real-valued matrices
$\mathbb{Z}$	Set of all integers
$\mathcal{C}^1$	Class of continuously differentiable functions
$(\cdot)'$ or $(\cdot)^T$	Transpose of a vector or a matrix $(\cdot)$
$\langle x, y \rangle$	$= \int_{-\infty}^{\infty} y^T(t)x(t)dt$
$\langle x, y \rangle_\ell$	$= \int_0^\ell y^T(t)x(t)dt$
$\ x\ $	$= \sqrt{\langle x, x \rangle}$ ( $\mathcal{L}_2$ -norm, energy of $x$ )
$\mathcal{L}_2$	Space of possibly vector valued signals $x$ for which the energy $\ x\  < \infty$
	for which $\ x\ _\ell < \infty \forall \ell \in \mathbb{R}$
$\ z\ _1$	$= \int_{-\infty}^{\infty}  z(t)  dt$

detail in [14] in the context of the repressilator network described in [3].

#### A. Notation

The notation used is summarized in Table III. We mostly follow the notation introduced in [18] and [19].

*Definition 1:* A function  $f : \mathbb{R}^n \mapsto \mathbb{R}^n$  is said to be *continuously (smoothly) differentiable* if the derivative exists and is continuous (smooth).  $\square$

*Definition 2:* A function  $f : \mathbb{R}^n \mapsto \mathbb{R}^m$  is said to be *Lipschitz* if there exists a constant  $L > 0$  such that, for all  $x_1, x_2 \in \mathbb{R}^n$ ,  $\|f(x_1) - f(x_2)\| \leq L\|x_1 - x_2\|$ .  $\square$

*Definition 3:* A system is said to be  $\mathcal{L}_2$  stable if the energy of its output is finite for every finite energy input.  $\square$

#### B. Background Results

Several results on synchronization of coupled oscillators exist and can be found in [20], [21], [22], [23], and references therein. Our tracking controller is based on the *dynamic inversion* (DI) theory presented in [13]. Let us consider

a specialized version of [13, Theorem 2] for a first order system. Consider a system described by

$$\dot{x}(t) = f(x(t), z(t), u(t)), \quad \dot{z}(t) = \zeta(x(t), z(t), u(t)), \quad (1)$$

where  $x(0) = x_0$  and  $z(0) = z_0$  for  $(x, z, u) \in D_x \times D_z \times D_u$  and where  $D_x, D_z, D_u \subset \mathbb{R}$  are domains containing the origin. The functions  $f, \zeta : D_x \times D_z \times D_u \rightarrow \mathbb{R}$  are continuously differentiable with respect to their arguments, and furthermore, assume that  $\partial f / \partial u$  is bounded away from zero in the compact set  $\Omega_{x,z,u} \subset D_x \times D_z \times D_u$  of possible initial conditions, i.e., there exists  $b_0 > 0$  such that  $|\partial f / \partial u| > b_0$ .

Let  $e(t) = x(t) - r(t)$  be the tracking error signal. Then, the open loop error dynamics are given by

$$\begin{aligned} \dot{e}(t) &= f(e(t) + r(t), z(t), u(t)) - \dot{r}(t), \quad e(0) = e_0, \\ \dot{z}(t) &= \zeta(e(t) + r(t), z(t), u(t)), \quad z(0) = z_0. \end{aligned} \quad (2)$$

We construct an approximate dynamic inversion controller:

$$\epsilon \dot{u}(t) = -\text{sign} \left( \frac{\partial f}{\partial u} \right) \mathbf{f}(t, x, z, u), \quad (3)$$

where

$$\mathbf{f}(t, x, z, u) \doteq f(e(t) + r(t), z(t), u(t)) - \dot{r}(t) - a_m e(t), \quad (4)$$

where  $a_m > 0$  gives the desired rate of convergence.

Let  $u(t) = h(t, e, z)$  be an isolated root of  $\mathbf{f}(t, e, z, u) = 0$ . The reduced system for the dynamics in (2) is given by

$$\begin{aligned} \dot{e}(t) &= -a_m e(t), \quad e(0) = e_0, \\ \dot{z}(t) &= \zeta(e(t) + r(t), z(t), h(t, e(t), z(t))), \quad z(0) = z_0. \end{aligned}$$

The boundary layer system is

$$\frac{dv}{d\tau} = -\text{sign} \left( \frac{\partial f}{\partial \tau} \right) \mathbf{f}(t, e, z, v + h(t, e, z)). \quad (5)$$

We assume that three conditions hold for all  $[t, e, z, u - h(t, e, z), \epsilon] \in [0, \infty) \times D_{e,z} \times D_v \times [0, \epsilon_0]$  for some domains  $D_{e,z}, D_v \subset \mathbb{R}$  which contain the origin:

- 1) The functions  $f, \zeta$  are such that their partial derivatives with respect to  $(e, z, u)$ , and the partial derivative of  $f$  with respect to  $t$  are continuous and bounded on any compact subset of  $D_{e,z} \times D_v$ . Further,  $h(t, e, z)$  and  $\frac{\partial f}{\partial u}(t, e, z)$  have bounded first derivatives with respect to their arguments, and  $\frac{\partial f}{\partial e}$  and  $\frac{\partial f}{\partial z}$  are Lipschitz in  $e$  and  $z$  uniformly in  $t$ .
- 2) The origin is an exponentially stable equilibrium of  $\dot{z}(t) = \zeta(x, z, h(t, 0, z))$ .
- 3) The term  $\left| \frac{\partial f}{\partial u} \right|$ , is bounded away from zero.

*Theorem 1:* ([13, Theorem 2])

Consider the boundary layer system (5). Suppose the above three assumptions hold. Then the origin is an exponentially stable equilibrium. Furthermore, let  $\Omega_v$  be a compact subset of  $R_v$ , where  $R_v \subset D_v$  denotes the region of attraction of

the autonomous system.

$$\frac{dv}{d\tau} = -\text{sign} \left( \frac{\partial f}{\partial u} \right) \mathbf{f}(0, e_0, z_0, v + h(0, e_0, z_0)).$$

Then for each compact subset  $\Omega_{z,e} \subset D_{z,e}$  there exist a positive constant  $\epsilon_*$  and  $T > 0$  such that for all  $t \geq 0$ ,  $(e_0, z_0) \in \Omega_{e,z}$ ,  $u_0 - h(0, e_0, z_0) \in \Omega_v$ , and  $0 < \epsilon < \epsilon_*$ , the system (1), (3) has a unique solution  $x_\epsilon(t)$  on  $[0, \infty)$  and  $x_\epsilon(t) = r(t) + \mathcal{O}(\epsilon)$  holds uniformly for  $t \in [T, \infty)$ .  $\square$

*Remark 2:* a DI-based controller may require high gains if small error margins are required. On such occasions, a filtered controller may have to be used. A filtered controller may potentially worsen the error margins, but can be designed to ensure stability as well as robustness (see the disturbance observer of [24]).  $\square$

*Remark 3:* If each subsystem in the given network can be made to oscillate, the phase difference between the oscillations need not be enforced directly. Instead, the interconnection gains can be chosen to ensure a desired phase difference [25].  $\square$

### C. DI Controller Synthesis for Our Oscillator Network

Control theoretic synthesis of such DI controllers is explained in detail in [14] in the context of the repressilator network described in [3]. In this paper, we use the same ideas to build a feedback controller for the oscillator network described in [2], which is a more complicated and more advanced system. Conceptually, our approach to synthesize the DI controller is exactly the same as the approach of [14] and we claim no originality on that count. Nevertheless, for the sake of completeness, we now outline that synthesis procedure. Our objective is to induce the desired oscillations in  $[T_{21}A_1]$  and  $[T_{12}A_2]$  using  $[A_1]$  and  $[A_2]$ , respectively, as control inputs. Note that the dynamic equations for  $[T_{12}A_2]$  and  $[T_{21}A_1]$  may not oscillate spontaneously even when coupled with  $[rI_2]$  and  $[rA_1]$  depending on the experimental parameters such as hybridization rates and initial DNA and enzyme concentrations. Furthermore, we assume that the  $[rA_1]$  and  $[rI_2]$  dynamics cannot be controlled actively. Hence, the desired phase relationship between  $[T_{12}A_2]$  and  $[T_{21}A_1]$  needs to be enforced via reference signals sent to the two systems. We propose a DI-based controller to induce oscillations in each switch that track reference signals. We develop a controller for one switch, and a similar controller can be implemented for the other switch. To overcome the limitations of closed systems and to allow real-time fine tuning of control inputs, we will assume the use of microchemostat as an experimental platform [26]. The state of switch can be read out real-time by fluorescence measurements [2], which can be compared with the reference signal in the controller. Then, the required control inputs are injected to the reaction chamber  $-A_j$  for positive inputs and its complement  $\bar{A}_j$  for negative inputs. An analogous control method was used in [17] to move system from a bistable parameter regime to a monostable regime and back.

The controller is developed hereafter using the symbols  $x, z$  and  $u$  for brevity of notation. The state  $x$  denotes

$[T_{21}A_1]$  or  $[T_{12}A_2]$ . The variable  $z$  represents  $[rA_1]$  or  $[rI_2]$ , respectively. The control input,  $u$ , denotes  $[A_1]$  or  $[A_2]$  as the case may be. Each switch can be expressed as a *linear time-varying* (LTV) system of the form:

$$\dot{x}(t) = -a(t)x(t) + \sigma(t) + g(z)u(t), \quad (6)$$

where  $z$  represents external dynamics which are *bounded input bounded output* (BIBO) stable with respect to  $x$ . Noise and external disturbances are captured in the term  $\sigma(t)$  which is assumed to be bounded with a bounded derivative.

*Remark 4:* Note that  $a(t)$  and  $g(z)$  are assumed known in this case. However, the model is only approximately valid so that a general control-theoretic approach applicable for unknown dynamic functions is of much use in the required controller synthesis.  $\square$

The control objective is to design  $u(t)$  to ensure that  $x(t)$  oscillates when both  $a(t)$  and  $g(z)$  are unknown. We assume that  $g(z) > 0 \forall z$ , i.e., the control effectiveness is positive, and that  $g(z)$  is smoothly differentiable for  $z > 0$  with a bounded derivative. Let  $r(t)$  denote the reference signal which needs to be tracked by a given switch of the oscillator network, where  $r(t)$  can be chosen as a sine wave with an appropriate phase for each component. Then, we write the error dynamics for  $e = x - r$ :

$$\dot{e} = -a_m e + \sigma + g(z)u - a_m r - \dot{r} + (a_m - a)x, \quad (7)$$

where  $a_m > 0$  ensures a desired convergence rate; in this equation, we have not stated the dependence on  $t$  explicitly. If we could ensure that  $g(z)u(t) + \sigma(t) - a_m r(t) - \dot{r}(t) + (a_m - a(t))x(t) = 0$ , then  $x(t)$  would be oscillatory. A DI-based control law given by

$$\dot{u}(t) = -k(g(z)u(t) - a_m r(t) - \dot{r}(t) + (a_m - a(t))x(t)) \quad (8)$$

ensures tracking with an error bounded above by  $\mathcal{O}(1/k)$ . However, note that  $a(t)$ ,  $\sigma(t)$  and  $g(z)$  are all unknown. The standard practice would be to design an adaptive law to estimate them [24]. Instead, using Eq. (7), we can rewrite the control law as

$$\dot{u}(t) = -k(\dot{e}(t) + a_m e(t)), \quad (9)$$

i.e., as

$$u(t) = -k_p e(t) - k_i \int_0^t e(t) \quad (10)$$

where  $k_p = k$ , i.e., the error bound is on the same order as the inverse of the proportional gain. To avoid the wind-up, we replace  $k_i$  with the anti-windup  $\Theta(k_i, e)$ , where

$$\Theta(k_i, e) = \begin{cases} k_i & \text{if } |e| < \bar{\theta}; \\ \bar{k}_i & \text{if } e \geq \bar{\theta}; \\ -\bar{k}_i & \text{if } e \leq -\bar{\theta}, \end{cases}$$

where  $\bar{\theta}$  and  $\bar{k}_i$  are thresholds of choice.

## V. SIMULATION RESULTS

The simulation results are shown in Fig. 2 for our oscillator network which is a slight modification of the first of the 3 designs in [2]. It comprises two dynamical systems,

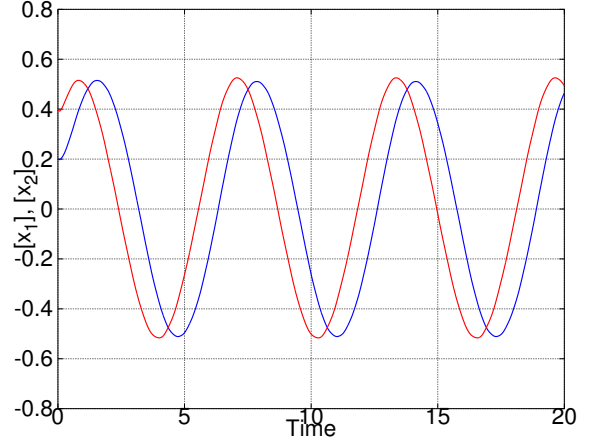

Fig. 2. Time histories of the states of the two switches. Here,  $[x_1]$  denotes the deviation from a baseline value in the concentration of  $T_{21}A_1$  and  $[x_2]$  denotes the deviation from a baseline value in the concentration of  $T_{12}A_2$ . The performance objective was to induce tunable oscillations in these two states with a phase difference of  $\pi/4$ . The simulation plots show that the performance objective is achieved satisfactorily.

each of which has to track an oscillatory trajectory. The periodic signals sent to the two subsystems are chosen to be identical, except for a phase difference. Moreover, periodic disturbances are added to the two subsystems. The  $z$  dynamics are driven by the state  $x$  of the other oscillator, in a way similar to the Kim-Winfree model. As Fig. 2 shows, the performance objective is achieved satisfactorily.

## VI. DISCUSSION

Synthetic biology is growing as an expansion of traditional biology discipline from natural organisms towards potential organisms [27]. Hence, making biological systems *engineerable* is a goal of engineers in the field of synthetic biology. Many technical and fundamental obstacles remain before the construction of synthetic biological systems can become routine. Due to the modular nature and programmable connectivity, DNA-based circuits operating in a simple *in vitro* environment offers a promising testbed for engineering biochemical systems. In this work, we focused on the two-switch oscillator synthesized in [2] as the control objective. In [2], Kim and Winfree explored the system for a wide range of parameters that resulted in an oscillatory response. However, these oscillations damped out eventually due to the limitations of closed system. One of the experimental difficulty was the accumulation of short degradation products, which induced slow-down of oscillation periods and damping of oscillations. Detailed mechanistic modeling provided a more complete explanation for the system behavior, but did not allow easy analytic exploration. In a subsequent work [12], the two-switch oscillator was connected to various downstream load processes, showing different extent of system sensitivity depending on the amount of load processes and the mode of coupling. In this work, a microchemostat platform ([26]) was assumed to overcome the limitation of closed systems

and to allow real-time input of reference signals. This would allow a more predictable system behavior with robust and sustained oscillations – making the proposed simple ODE model as a reasonable description of oscillator network. We have shown that the DI-based controller approach ensures tunable robust oscillations in the two-switch oscillator system following reference signals with guaranteed bounds. This controller approach would be particularly relevant when the oscillator is coupled to load processes with unknown dynamics. We believe our DI controller will be applicable to the other oscillator networks in [2] as well as other DNA-based synthetic circuits *in vitro*. Presently, we are working on the experimental implementation of the controller using chemical reaction networks. In addition, we are exploring the use of sparse and possibly aperiodic signals as the exogenous inputs to the system so as to build the desired oscillations.

## VII. CONCLUSION

In biological networks, oscillators serve as molecular clocks that govern several important cellular processes such as cell division and global gene expression. Recent progress in *in vitro* synthetic biology demonstrated the use of simplified synthetic gene analogues to construct oscillators [2] that can be used to orchestrate other molecular processes *in vitro* [12]. However, partly due to the closed nature of the implementation, the oscillators synthesized in [2] do not exhibit sustained oscillations. In addition, their robustness to disturbances and modeling uncertainties has also been left uncharacterized. Assuming an open system implementation, we demonstrate how the well-known dynamic inversion technique can be directly used to synthesize feedback controllers that ensure sustained and synchronized oscillations. The tunability is achieved by injecting a function of the desired signal as the input to the system.

## VIII. ACKNOWLEDGMENT

We thank Anna Waldo (MIT) for preliminary work on this draft. We thank Prof. Richard Murray (Caltech), Prof. Naira Hovakimyan (UIUC), Prof. Soon-Jo Chung (UIUC), and Dr. Aditya Paranjape (UIUC) for useful discussions.

## REFERENCES

- [1] A. J. Hockenberry and M. C. Jewett, “Synthetic *in vitro* circuits,” *Current Opinion in Chemical Biology*, vol. 16, pp. 1–7, 2012.
- [2] J. Kim and E. Winfree, “Synthetic *in vitro* transcriptional oscillators,” *Molecular Systems Biology*, vol. 7, no. 465, February 2011.
- [3] M. B. Elowitz and S. Leibler, “A synthetic oscillatory network of transcriptional regulators,” *Nature*, vol. 403, no. 6767, pp. 335–8, January 2000.
- [4] N. Strelkova and M. Barahona, “Switchable genetic oscillator operating in quasi-stable mode,” *Journal of the Royal Society Interface*, vol. 7, no. 48, July 2010.
- [5] T. Danino, O. Mondragon-Palomino, L. Tsimring, and J. Hasty, “A synchronized quorum of genetic clocks,” *Nature*, vol. 463, January 2010.
- [6] J. Garcia-Ojalvo, M. B. Elowitz, and S. H. Strogatz, “Modeling a synthetic multicellular clock: repressilators coupled by quorum sensing,” *Proceedings of the National Academy of Sciences*, vol. 101, July 2004.
- [7] J. Kim, D. Shin, S. Jung, P. Heslop-Harrison, and K. Cho, “A design principle underlying the synchronization of oscillations in cellular systems,” *Journal of Cell Science*, vol. 123, no. 4, February 2010.
- [8] M. Tigges, T. Marquez-Lago, J. Stelling, and M. Fussenegger, “A tunable synthetic mammalian oscillator,” *Nature*, vol. 457, no. 4, January 2009.
- [9] E. Fung, W. W. Wong, J. K. Suen, T. Bulter, S. Lee, and J. Liao, “A synthetic gene-metabolic oscillator,” *Nature*, vol. 435, May 2005.
- [10] M. Atkinson, M. Savageau, J. Myers, and A. Ninfa, “Development of genetic circuitry exhibiting toggle switch or oscillatory behavior in *escherichia coli*,” *Cell*, vol. 113, pp. 597–607, 2003.
- [11] K. Montagne, R. Plasson, Y. Sakai, and Y. Rondelez, “Programming an *in vitro* DNA oscillator using a molecular networking strategy,” *Molecular Systems Biology*, vol. 7, no. 466, February 2011.
- [12] E. Franco, E. Friedrichs, J. Kim, R. Jungmann, R. Murray, E. Winfree, and F. Simmel, “Timing molecular motion and production with a synthetic transcriptional clock,” *PNAS*, vol. 108, no. 40, pp. E784–E793, October 2011.
- [13] N. Hovakimyan, E. Lavretsky, and A. Sasane, “Dynamic inversion for nonaffine-in-control systems via time-scale separation: Part I,” *Journal of Dynamical and Control Systems*, vol. 13, no. 4, April 2007.
- [14] V. V. Kulkarni, A. A. Paranjape, M. Riedel, and S.-J. Chung, “Robust tunable transcriptional oscillators using dynamic inversion,” in *IEEE Conference on Decision and Control*, Maui, Hawaii, December 2012 (submitted).
- [15] J. J. Hopfield, “Neurons with graded response have collective computational properties like those of two-state neurons,” *PNAS*, vol. 81, no. 10, pp. 3088–3092, May 1984.
- [16] J. Kim, J. Hopfield, and E. Winfree, “Neural network computation by *in vitro* transcriptional circuits,” in *Advances in Neural Information Processing Systems (NIPS)*, vol. 17, no. 681–688, 2004.
- [17] J. Kim, K. White, and E. Winfree, “Construction of an *in vitro* bistable circuit from synthetic transcriptional switches,” *MolSyst Biol*, vol. 2, no. 68, 2006.
- [18] J. Willems, *The analysis of feedback systems*. Cambridge, MA: The MIT Press, 1971.
- [19] C. Desoer and M. Vidyasagar, *Feedback systems: Input-output properties*. Academic Press, 1975.
- [20] G.-B. Stan and R. Sepulchre, “Analysis of interconnected oscillators by dissipativity theory,” *IEEE Transactions on Automatic Control*, vol. 52, no. 2, pp. 256–270, February 2007.
- [21] S. J. Chung and J. J. E. Slotine, “On synchronization of coupled Hopf-Kuramoto oscillators with phase delays,” in *IEEE Conference on Decision and Control*, Atlanta, GA, December 2010, pp. 3181–3187.
- [22] A. O. Hamadeh, G.-B. Stan, and J. M. Goncalves, “Constructive synchronization of networked feedback systems,” in *IEEE Conference on Decision and Control*, Atlanta, GA, December 2010, pp. 6710–6715.
- [23] A. O. Hamadeh, G.-B. Stan, and R. Sepulchre, “Global state synchronization in networks of cyclic feedback systems,” *IEEE Transactions on Automatic Control*, vol. 57, no. 2, February 2012.
- [24] E. Kharisov, K. Kim, X. Wang, and N. Hovakimyan, “Limiting behavior of  $\mathcal{L}_1$  adaptive controllers,” in *Proc. AIAA Guidance, Navigation and Control Conference*, Portland, OR, April 2011, pp. 451–456.
- [25] S. Varigonda and T. Georgiou, “Dynamics of relay-relaxation oscillators,” *IEEE Transactions on Automatic Control*, vol. 1, no. 46, pp. 65–77, 2001.
- [26] F. K. Balagadde, L. You, C. L. Hansen, F. H. Arnold, and S. R. Quake, “Long-term monitoring of bacteria undergoing programmed population control in a microchemostat,” *Science*, vol. 309, no. 5731, pp. 137–40, July 2005.
- [27] M. Elowitz and W. A. Lim, “Build life to understand it,” *Nature*, vol. 468, pp. 889–890, 2010.